



NEWS THE **ASSAC** PROJECT

- ↻ The Beginnings
- ↻ The Present
- ↻ More than 100 units sold
- ↻ ASSAC - The New Generation

Also in this issue

INSTALLATIONS

- ↻ Basell UK
- ↻ Infosa
- ↻ Tramesa
- ↻ Schmidt
- ↻ Talke
- ↻ Semences Druaisses
- ↻ Cap Seine
- ↻ Vali Comercial
- ↻ Agribrands Purina
- ↻ Norel Misr

LAST-MINUTE

- ↻ Representation in Poland
- ↻ Taropak
- ↻ Representation in Saudi Arabia

TRADE FAIRS

- ↻ Propak
- ↻ Expopack
- ↻ Figap
- ↻ Emballage

The ASSAC Project

We need to go back to the late eighties to find the beginnings of the ASSAC project.

The Beginnings

● PAYPER's progressive penetration into the chemical and petrochemical industries had by then already placed us in a leading position in the ranking of suppliers to the large multinationals in the sector, such as BASF, Bayer, Solvay, Hoechst, Elf Atochem, Aiscondel, Repsol, Cepsa, Dow Chemical, General Electric Plastics, Rhone Poulenc, etc.

The common denominator between all these companies is their strict quality and service requirements.

The aforementioned companies, amongst many others, began replacing the usual valve bag packaging system with bags made by the packaging machine itself from a tubular reel of polyethylene.

This tendency, which was being promoted from Germany by both raw materials manufacturers and local bag manufacturers, represented a significant leap forward in automation and reliability, with a considerable saving in packaging costs.

This system is today well known by its initials FFS (Form-Fill-Seal)

1990 marked a significant change in the packaging world in this industry

PAYPER wished -and still wishes- to remain an industry leader and therefore needs to adapt to trends dictated by the market, to continue at the forefront of the international bagging scene.

The plastic valve bag used since then is very costly, due to the complexity of its manufacturing process, which requires extremely expensive equipment: this can only be recouped by charging very uncompetitive prices.

The Past

It is against this backdrop that

02
N
03

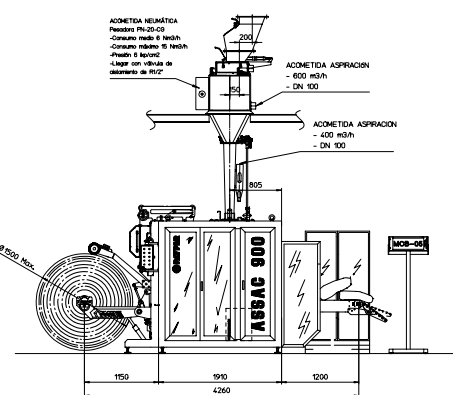

the ASSAC range was created. Sixteen years ago, the project's first machine, ASSAC-900, first saw the light of day.

It was used in 1992 as a test bed in the Repsol Química chemical plant in Puertollano, where, after a year in operation, it obtained highly satisfactory results –to such an extent that, in the following year, Repsol requested two more units.

At the same time, the ASSAC found another application in the ceramic industry and, during the course of 1994 and 1995 three units were sent to three of the most prestigious companies in the industry: Esmaltes, Cookson

Mattey Ceramics and Fritta.

Tarragona's petrochemicals

industrial area, where PAYPER has been offering its services for 20 years, responded

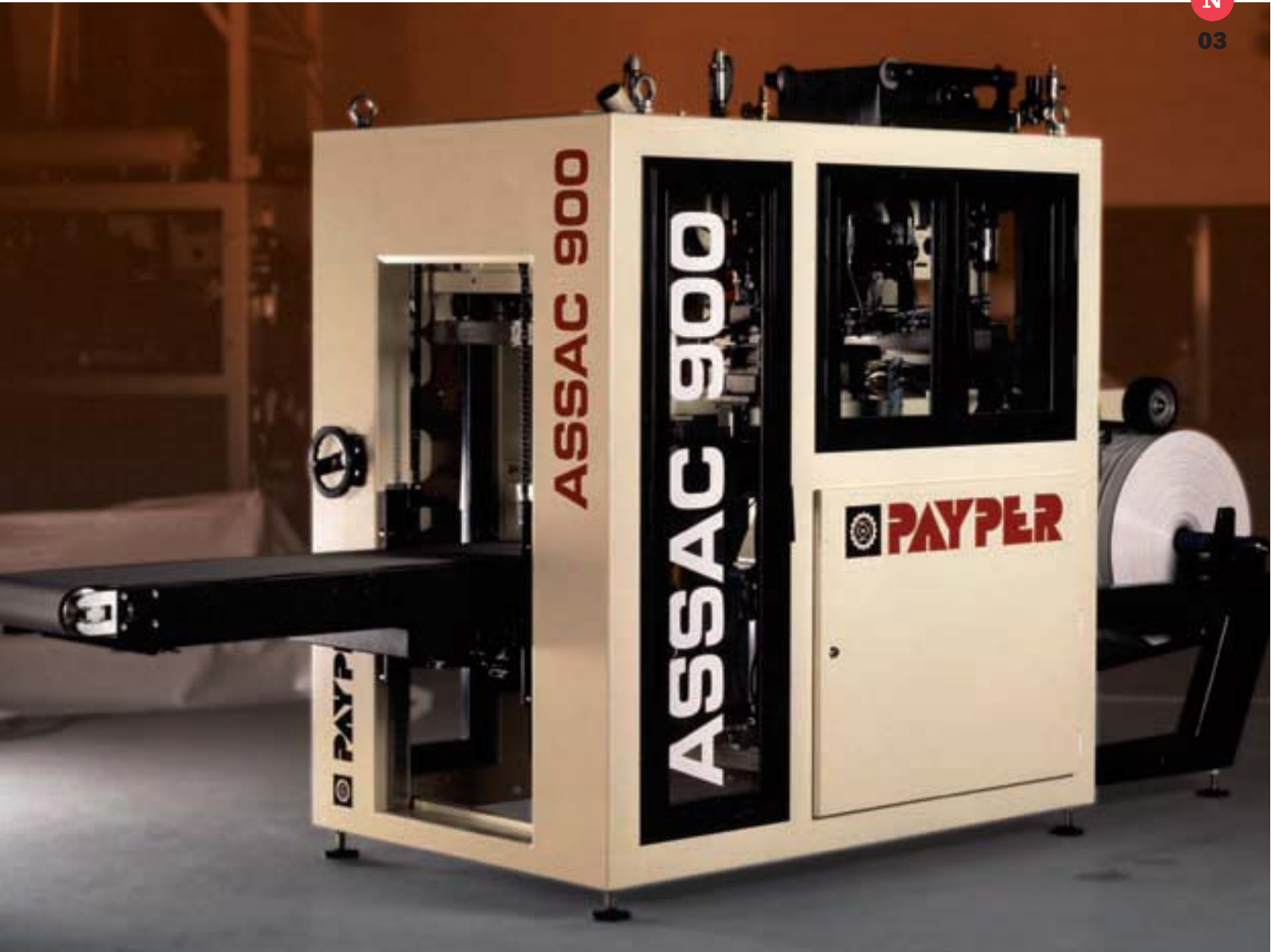
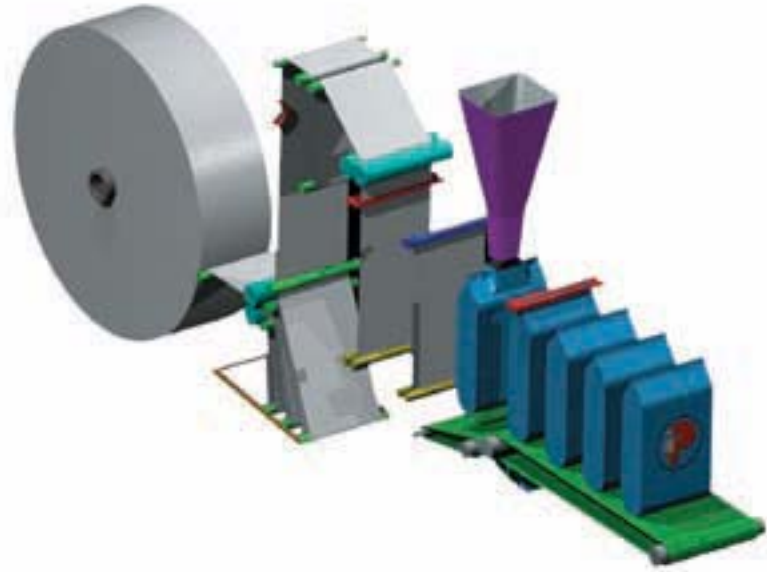

The ASSAC Project



positively to the promotion of the ASSAC project and, in 1995, the company Taqsa/Hoechst Ibérica acquired another ASSAC-900.

At this time, when the ASSAC ceased being a project to become a reality, our R&D Department continued to devise new applications for this machine.

Efforts were focused on increasing production capacity, one of the industry's demands. This gave rise to the ASSAC-1200.

In 1996, by which time the division had become consolidated, the Brazilian company Ipiranga Petroquímica acquired two machines. ASSAC thus became known on the international market. In this year, a number of machines were supplied to chemical companies such as Resisa, Repsol, Transcolor, Bayer and General Química. The same year also saw the supply of the first ASSAC-1200 to the firm Taqsa/Hoechst Ibérica, following the good results obtained with its predecessor. Also in 1996, the two largest projects to date, which included ASSAC machines,

were rolled out: the first involved the packaging equipment for a petrochemical plant built by the company Repsol-Polymed in the north of Algeria, and the second included the entire packaging logistics for the new plant built by the multinational General Electric Plastics in Cartagena, Spain.

1997 witnessed the signing of an important agreement with German logistics company Karl Schmidt Spedition GmbH & Co., which permitted the supply of eight machines to BASF and a further two to Montell, both to plants located in Germany. Machines were also supplied to Basell in Spain and Schulman in Mexico.

In 1998, ASSAC machines were sold to Erkol in Spain, a second to Schulman in Mexico and to the company TCT in France.

1999 saw the launch of the ASSAC-1400. It was a good year for the division's consolidation abroad. One machine was installed in Iran, two in Brazil and three in Mexico, in addition to three more in Spain.

At the same time, a new version



04

N

05

Efforts were focused on increasing production capacity, one of the industry's demands. This gave rise to the ASSAC-1200.

ASSAC thus became known on the international market in 1996.

called the ASSAC-400 was developed, which integrated a weighing function in the bagging mouth, making it ideal for industries requiring low production levels and making frequent product changes.

Its main advantages lie in the ease of cleaning to prevent cross-contamination and the ability to place silos or other feed systems at a considerably lower height, with the consequent saving costs.

2000 ended with a total of 13 ASSAC machines sold, one in ➔



1999 saw the launch of the ASSAC-1400.



The ASSAC Project

France and the others in Spain.

In 2001 and 2002, further machines were supplied to Spain, Germany, Mexico and the United States.

In 2003, new ASSAC versions were developed, whose fields of application covered the handling of powdered products and highly-corrosive products such as fertilisers and salt. During the year, the first examples

were installed in Spain, again with satisfactory results. At the same time, demand was growing abroad, and a number of machines left PAPER for Germany, Portugal and Mexico. It was in this latter country that an important agreement was signed with state-owned company Petróleos Mexicanos (Pemex), which included the supply of four machines.

In 2004 the new, faster ASSAC-1600 appeared. The year began with the supply of three new machines for Pemex, in Mexico. The same country also saw the installation of three further machines for other petrochemical companies. Additionally, a further ASSAC was installed in France, two in Belgium and four in Spain, two for the bagging of fertilisers.

2005 saw the sale of ten

In 2003, new ASSAC versions were developed, whose fields of application covered the handling of powdered products and highly-corrosive products such as fertilisers and salt.

06
N
07

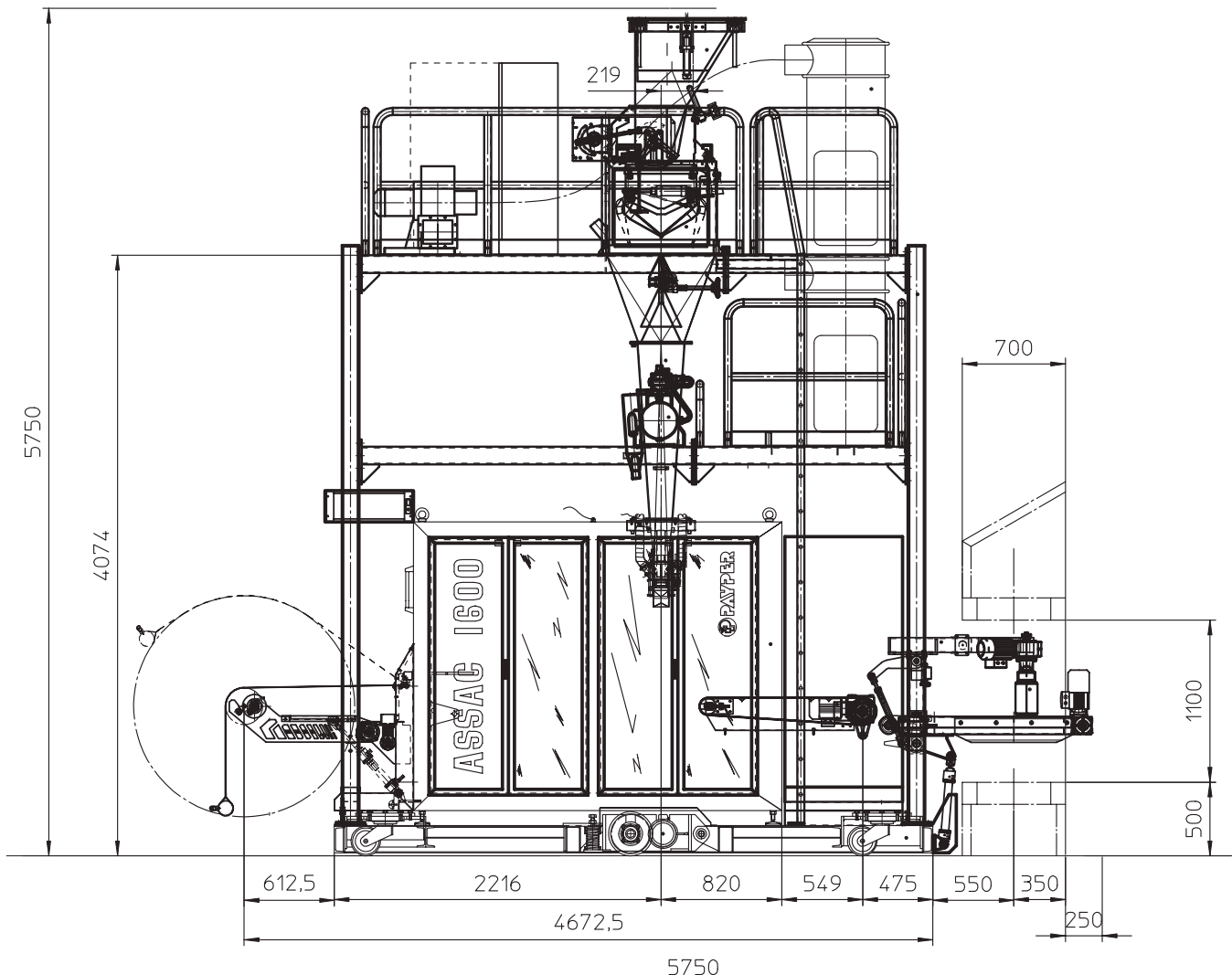

machines: four in Belgium, one in Germany (supplied to the logistics company Talke), a new high-speed ASSAC-1600 for Pemex in Mexico, two machines in France and one in Spain.

2006 is also proving to be a good year for the ASSAC division, with the securing of 15 agreements. High-speed lines are being supplied to Basell in the UK and Lanxess in Spain. Four machines have been built for the packaging of fertilisers. A new high-speed line for dry and damp salt of different grades is being brought on line. A new machine was ordered from Mexico and four more installed in Belgium. Finally, an ASSAC was ordered for the handling of extremely fine products. ■

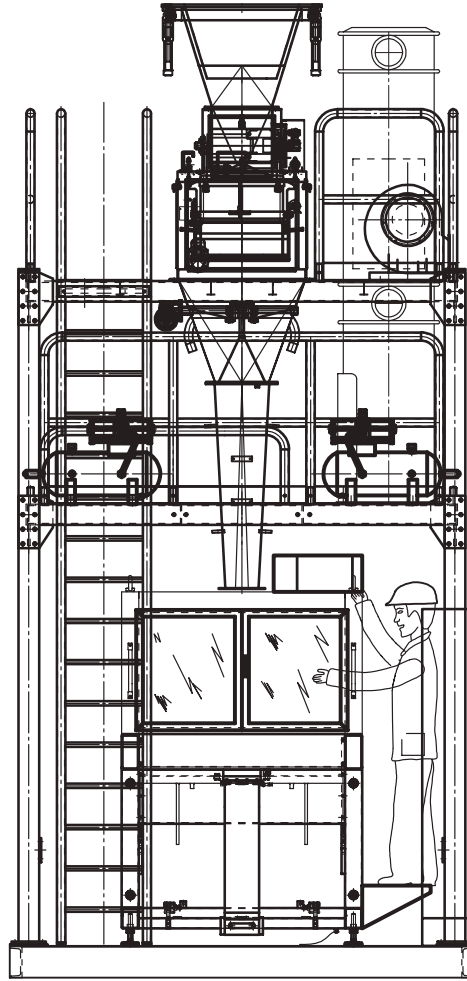

For a:

▼ Clean

⚡ Fast

📏 Accurate

🛡️ Guaranteed

bagging process



BASELL

United Kingdom



Manchester, Exchange Square

Petrochemical multinational BASELL has contracted PAPER to supply the bagging and palletising line for its polypropylene production (PP) centre in Carrington, close to Manchester, in the United Kingdom.

The following items are being supplied:

- A PN-90/CGS weight scale with servomotor feeder.
- An ASSAC 1600 FFS (Form-Fill-Seal) bagger.
- A motorised platform which moves in line on rails. The packaging tower (scale and bagger), as well as the aspiration system –made up of a filter and the relevant piping– is located on this platform.

- Detector of metals on belt.
- System for checking weight on belt.
- Automatic rejection of out-of-tolerance bags by weight or using a metal detector alarm.
- High-level Chimipal 1800 automatic palletiser from Newtec Bag.

Once the pallet has been prepared it is directed to a shrink-wrapper for covering.

The entire bagging line moves under a battery of 12 PP silos which converge onto four bagging points.

The average production rate of the line is 1,200 bags per hour, with a peak of 1,500 bags per hour. ■

The entire bagging line moves under a battery of 12 PP silos which converge onto four bagging points.



INFOSA

Sant Carles de la Ràpita (Tarragona)

Already fully operational is the new packaging line (bagging, palletising and wrapping) acquired by INFOSA for its Delta del Ebro salt works at Sant Carles de la Ràpita (Tarragona).

The actual production rate of the bagging line is **1,300 25kg bags per hour** under a best-case scenario (i.e. with dry fine salt).

Worth highlighting is the wide variety of salt types handled: fine and granulated, both dry and damp.

The entire packaging line has been made from 314 and 316 stainless steel to combat the highly corrosive nature of the product, as well as the salty atmosphere of the plant, which lies only a few metres from the sea. ■



The net weight scales include an innovative servomotor belt feeding system with a performance in excess of 20 cycles per minute.

The bagging station features a product acceleration tube with an agitation system due to the poor fluidity of damp salt.



TRAMESA

Tránsitos del Mediterráneo (Málaga)

Bagging of fertilisers through FFS

The company Tránsitos del Mediterráneo, located in Málaga, produces and distributes granular fertilisers in 25 and 50 kg bags.

To do this, it boasts a fertiliser packaging line made up of electronic net weight scales and an automatic ASSAC-900 FFS bagger, based around a tubular reel.

The line's capacity has been estimated at around 1,000 25kg bags per hour.

10
N
11

Due to the corrosive nature of the products to be bagged, all the equipment has been made entirely from stainless steel.

Additionally, the bagging tower



has been covered with an enclosure to prevent damp reaching the fertiliser powder

(which is extremely hygroscopic), something that would make its corrosiveness critical. ■



SSB Wägetechnik

(Belgium/Germany)

True to our policy of expansion in Europe, some years ago we began our relationship with our representatives in Germany, SSB Wägetechnik, a firm with great experience in the bagging machinery industry, of great commercial and technical abilities.

This has allowed us to secure some significant projects recently awarded by important logistics companies headquartered in Germany and who operate in the field of petrochemicals on a world-wide scale.

The most recent and significant are for:

Karl Schmidt Spedition

■ Supply of a twin bagging platform installation to BASF for its production centre in Antwerp, Belgium: FFS bagging installation with a capacity of up to 4,000 bags per hour. Each platform includes two ASSAC-900 stations for the polystyrene and ABS plant.



Talke

■ An FFS bagging line for BASF at its plant in Schwarzheide, Germany, which produces glass fibre polyamides (a highly abrasive product). The reel is made out of aluminium to prevent the oxidation of the polyamide, and the entire installation has been designed so that it can be cleaned with water leaving no remains.



Our collaboration with the most prestigious petrochemical companies and our ability to successfully participate in projects with important levels of difficulty and demands in terms of application and performance have allowed us to make a qualitatively significant leap forward on the international FFS bagging equipment manufacturer scene.

Today, thanks to this level of references, we can confidently state that Payper is one of the world's leading suppliers of bagging equipment to the petrochemical industry. ■

Karl Schmidt Spedition
Two bagging platforms.

Talke
One bagging line.

10

N

11

ASSAC

S10

L10

M10

F10

The new generation is already running



12
N
13



This year has witnessed the launch of our new FFS bagging stations, *ASSAC^{ST10}*, *ASSAC^{L10}* and *ASSAC^{M10}*. Technology advances rapidly, making systems, devices and materials that were valid but a few years ago easily improvable today. The new ASSAC bagging machines incorporate the latest advances in design, automation and materials.

The first noticeable change in comparison with previous models –without even needing to see the machine– involves the name.

The entire ASSAC range changes its name.

The figures 400, 900, 1200, 1400 and 1600, with their production speed connotations, are replaced by alphanumeric codes, in line with the rest of the PAYPER product range.

More than 100 ASSAC machines are currently operational.

Our customers are highly satisfied and prove this with their loyalty to us.

For example, several of the most well-known companies have purchased a more than 10 units each.

Our R&D Department continues working to achieve even better performance and new applications. ➔



ASSAC new generation, whose first machine is the S10, offers a wide range of advantages and performance improvements over the previous ASSAC range, which makes it a true bagging station. They can be summarised as follows:

➔ **Speedy**

Up to 2000 bags per hour depending on the model.

➔ **Reliable**

Incorporates the experience gained with over 100 machines currently in operation.

➔ **Smoothness of operation**

Incorporates the most innovative drive systems on the market. All movements are controlled by frequency converters to prevent brusque starting and stopping, which means less mechanical fatigue in its components.

➔ **Tough**

For the above reasons, and thanks to its mechanical conception, this machine has been designed and built to last.

➔ **Silent**

The translation and guide systems have been optimised to minimise the emission of decibels.

➔ **Compact**

Incorporates the control cabinets in the chassis itself, and some of the modules are distributed in the bagging machine itself.

➔ **Accessible**

Each and every one of the items which may need some form of maintenance is perfectly accessible to operators.

➔ **Easy to use**

The self diagnosis touch-screen includes all the information required for users to resolve the majority of incidents on their own.

➔ **Versatile**

It has automatically-adjusting elements which permit the handling of different formats. Adjustments are carried out in a few seconds, controlled by the operations touch-screen.

➔ **Profitable**

This bagging machine's productivity and reliability, when combined with its unbeatable value for money, permit an important saving in packaging unit costs and thus a quick return on investment.

➔ **Attractive**

With its innovative, eye-catching design.



The Future

PAYPER installs future today

The future will soon become reality, and its name is *ASSAC^{F10}*.

These are machines designed to achieve rates of 2,000 bags per hour.

These high-performance versions will be available shortly. ■



SEMENCES DRUAISSES/CAP SEINE

France

In collaboration with our representatives in France, Newtec Bag Palletizing, we have supplied two automatic high-production lines. Payer has supplied the

bagging equipment and Newtec has then installed a high-level Agropal palletiser.

The capacity of both lines is

1,000 25kg bags per hour, and they comprise a PN-90/CGS servo feeding scale and a CSA-100 bag placer.

SEMENCES DRUAISSES in Dreux (Vernouillet)

Bagging of seeds



16
N
17

CAP SEINE in Rouen

Bagging of cattle feed



Includes a station adjacent to the bag placer (between the empty bag store and the central chassis), which permits the automation of the process of labelling the empty bags. ■

AGRIBRANDS PURINA/VALI COMERCIAL

Mexico

Agribands Purina

Agribands Purina, a company belonging to the CARGILL group, is located in Guadalajara (Jalisco).

It has recently acquired a semi-automatic feed and corrector bagging line.

Especially noteworthy is the double dispensing system made up of:

- Spreader: for correctors. Planned production rate is 6 to 8 bags per minute.
- Conveyor belt: For meal and pellet feed. Some of the meals include a significant percentage of molasse, and thus production rate range is broad, between 8 to 12 bags per minute.

Both dispensing systems come together in the same bag filling mouth.

Vali Comercial

We have recently installed three semi-automatic feed (meal and pellet) bagging lines for the firm VALI COMERCIAL, in San Luis Potosí (Mexico).

Two of them comprise PN-25/CT net weight scales, and are designed to achieve a production rate of 10-12 bags per minute.

The third line is a PB-12/CG gross weight model whose production rate is around 6 bags per minute. ■

Two important Mexican animal feed companies acquire baggers for their new production lines.

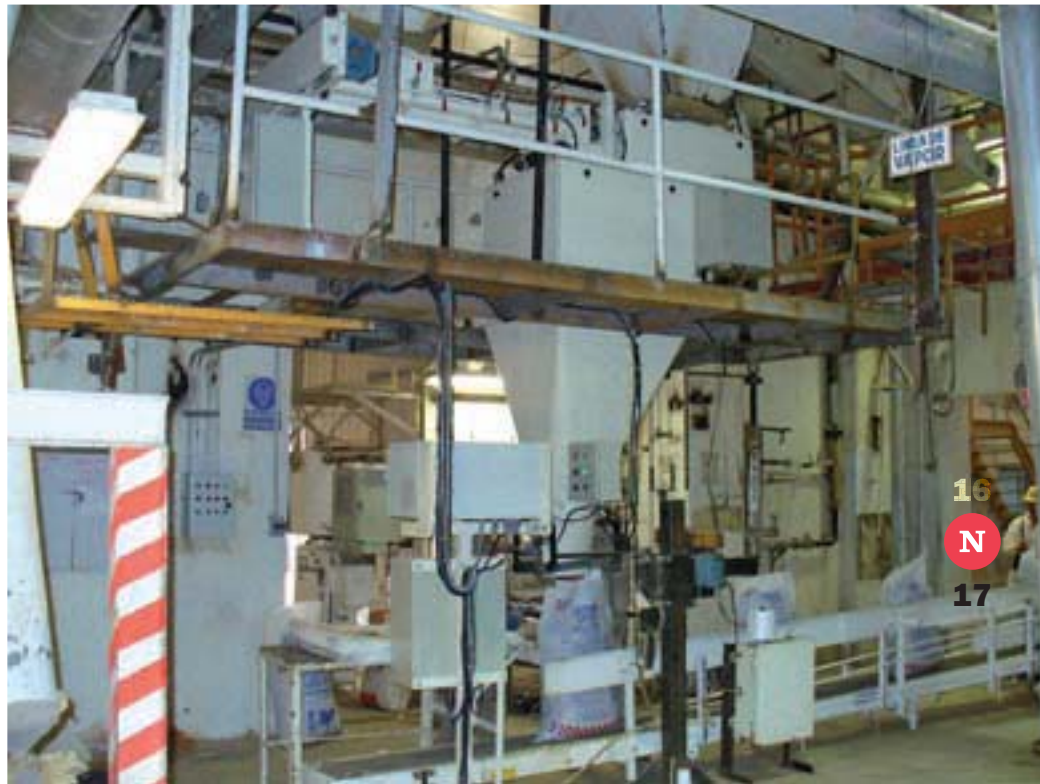

16
N
17



Sales representatives in Poland

The company "ALIMA-PACK SYSTEMY PAKOWANIA" SP. Z O.O., with offices in Sroda Wlkp. (in the Poznan area), became our representative in Poland in September.

ALIMA-PACK is a company belonging to the ALIMA-BIS group, which has a consolidated presence on the Polish market, where its activities have been focused mainly on the dairy products sector for the past 19 years. The ALIMA-PACK division's main activity is the sale of bag

filling and sealing equipment. It can thus offer customers an integrated solution for the entire bagging line.

We have recently carried out a number of promotional actions to, firstly, make the PAYPER name known in Poland before securing our first orders there.

TAROPAK 2006 Poznan (Poland)

We recently participated in the TAROPAK trade fair in Poznan, with a joint stand, which saw the commencement of interesting projects and which acted as a forum for progressing in others that had previously started. ■

 taropak2006



Poznan



18
N
19

Sales representatives in Saudi Arabia

The company AQTE, with headquarters in Jubail, is specialized in the furniture of industrial products for the petrochemical industry, and is our representative in Saudi Arabia since last few months.

Jubail is the most important petrochemical area in the country, close to Dammam, an important industrial centre and commercial port.

We have already done some actions to promote the PAYPER name into the Saudi market as a first step for the achievement of first references.

And we have already achieved our

first references. We have recently signed an important contract with the company PETROKEMYA, belonging to SABIC group, which includes the supply of 2 FFS bagging machines model ASSAC to pack polystyrene from tubular film.

We can point out these mentioned bagging lines that will be working before next summer. SABIC

is one of the most important petrochemical groups in the world. ■



Al Jubail

EMBALLAGE 2006 - Paris



We have been attending at the EMBALLAGE 2006 packaging trade show, held in Paris from 20 to 24 November.

On this occasion, we have exhibit our new range of ASSAC baggers, specifically the **ASSAC L10** model, on the stand of our representative in the country, Newtec Bag, the manufacturer of bag palletising systems.

We have been regularly attending this show for the last 15 years, as the French market of is of key importance to us.

France is our leading market in terms of export sales.

We currently have a portfolio of more than 100 automatic installations in the country, principally in the agro-food sector, although we have also supplied numerous important installations to both the chemical and construction industries. ■



PROPAK 2006 - Shanghai (P.R. China)

We also exhibited at the PROPAK 2006 International Show in Shanghai, China.



This was the 12th edition of China's largest and most important processing and packaging technology trade fair. **PAYPER participated jointly with our agents in China, Melchers Techexport**, together with other represented European companies.

The show was a great success, with initial contacts being established with potential users and progress being made on matters already initiated.

Additionally, the show proved the perfect occasion for bringing together the entire Melchers Techexport sales network, and was used to provide training sessions for representatives from the different provinces of China, as

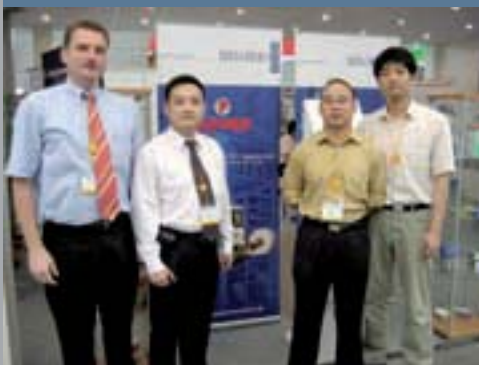

well as from the other offices in countries in the regions, such as South Korea, Malaysia and Indonesia. ■

EXPOPACK 2006 - Mexico

We took part in the most recent ExpoPack trade fair held in Mexico City.



Payper is already a well-known name and a consolidated presence in the Mexican market, where we have made numerous installations in the three industries in which we are active: chemical/petrochemical, agro-food and construction.

Worthy of especially note is our leadership in the supply of FFS equipment, especially for the petrochemical industry.

Our participation was a great success, leading to a good number of new projects.

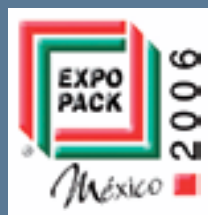

More than 30,000 purchasers from Mexico and Central America attended EXPOPACK México and PROCESA in search of the latest trends in packaging and conversion technology. ■



FIGAP 2006 - Guadalajara, Jalisco (Mexico)

At this, the first time we participated at the International Forum for the Livestock, Poultry and Pig Industries, FIGAP 2006, held in Guadalajara (Jalisco) at the end of October, we received a large number of visits from both customers and companies interested in our equipment, thereby consolidating PAYPER's position as the supplier of choice of bagging machinery in Mexico.

The show provided an unsurpassable opportunity to bring together our national representatives.

Over the course of the three days of the show, a great number of contacts were made with visitors from the agro-feed industry, which have led to a significant number of bagging line projects to be carried out in the short term. ■



NOREL MISR

Egypt

We have recently installed a bagging line for calcium soap (which is used in the production of feed for ruminants) for the firm Norel Misr, at their installations in Suez (Egypt).

The line is made up of a PN-20/CG net weight scale, designed to achieve production rates of 20 tonnes per hour. It also includes a set of extraction conveyor belts, and equipment for the handling and preparation of bags (turner and press), as well as a sealing system (sewing machine).

This investment forms part of Norel Misr's policy in the area, the first step of which is to supply a quality product, with especial regard to weighing accuracy. Future plans include greater automation of the packaging line. ■



20

N

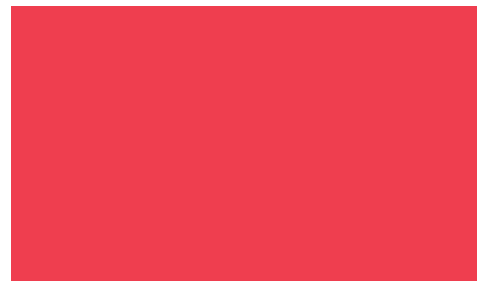

Baudelaire, Suez seaport



PAYPER
SACKING TECHNOLOGY

Pol Ind El Segre parc 115 25191 Lleida (SPAIN)
Tel. +34 973 216 040 Fax. +34 973 205 893
payper@payper.com www.payper.com

WE INSTALL **FUTURE TODAY**